



CATALOG OF REPLACEMENT PARTS

MODEL FP400 FOOD PROCESSOR

FP400	ML-104751
FP400C	ML-134183



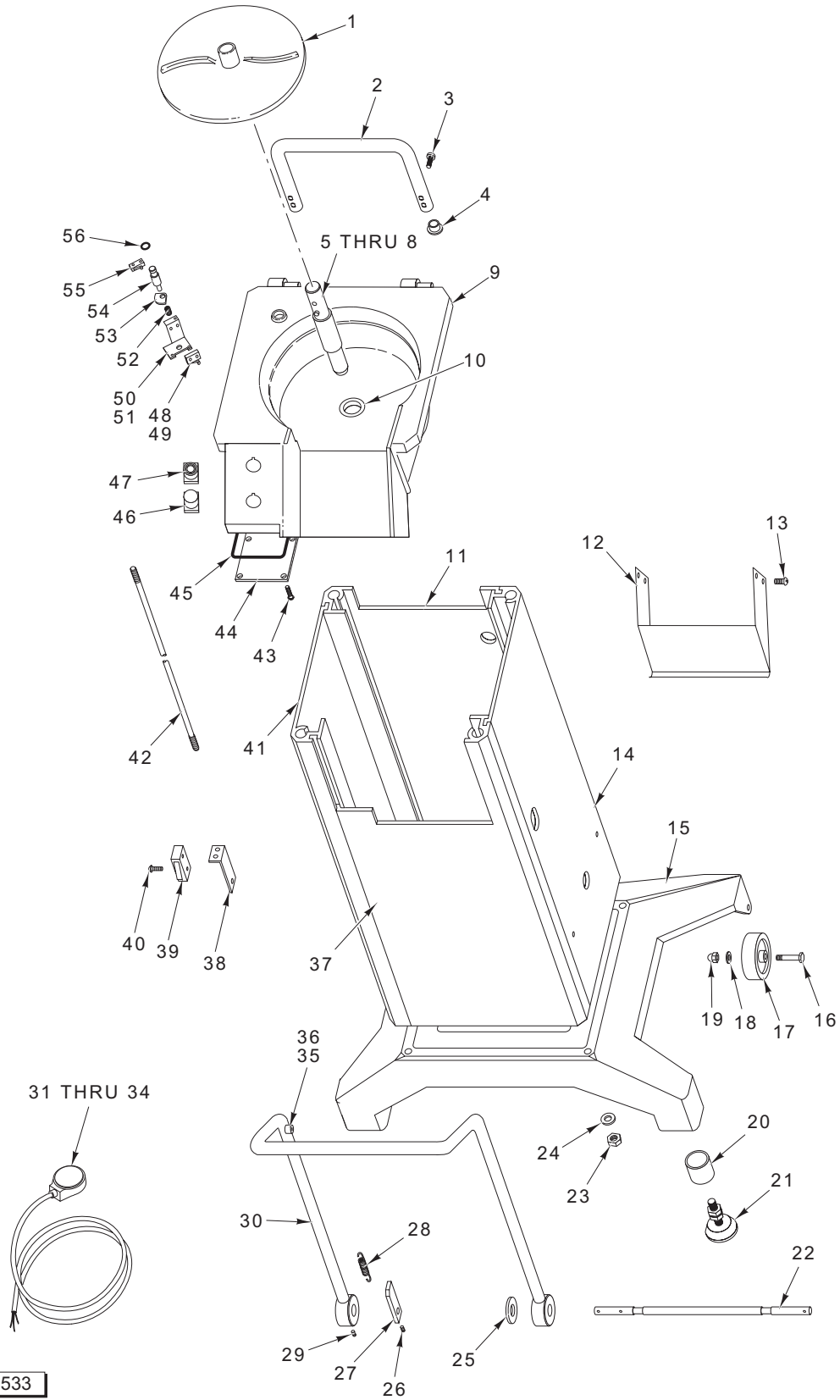

PL-55533

HOUSING UNIT

HOUSING UNIT

ILLUS. PL-55533	PART NO.	NAME OF PART	AMT.
1	00-439142	Ejector	1
2	00-478830	Handle – Knife Chamber	1
3	SC-124-26	Mach. Screw M8 x 1.25 x 30mm Slotted Pan Hd. (SST)	2
4	00-478881	Plug	1
5	00-478850	Shaft – Knife Assy.	1
6	00-439124	Pin – Carrier	1
7	SC-121-48	Set Screw M8 x 1.25 x 12mm Slotted Hdls. Cup Pt. (SST)	1
8	00-478844	Pin	1
9	00-478833	Housing – Knife	1
10	00-439129	Washer – Seal	1
11	00-478902	Housing – Back	1
12	00-478832	Guard – Chute	1
13	SC-124-25	Mach. Screw M5 x 0.8 x 12mm Slotted Truss Hd. (SST)	4
14	00-478901	Housing – Right	1
15	00-478834	Base	1
16	SC-124-22	Cap Screw M8 x 1.25 x 70mm Hex Hd. (SST)	2
17	00-478877	Wheel	2
18	00-478885	Washer – Wheel	2
19	NS-048-42	Nut M8 x 1.25 Crown (SST)	2
20	00-478845	Tube – Protection	2
21	00-478878	Foot – Rubber	2
22	00-478829	Shaft – Lock Handle	1
23	NS 047-36	Nut M8 x 1.25 Hex (SST)	1
24	WL-019-74	Lockwasher M8 Helical (SST)	1
25	00-478823	Bushing – Lock Handle	2
26	SC-124-27	Set Screw M8 x 1.25 x 15mm Slotted Hdls. Dog Pt. (SST)	1
27	00-478828	Stop – Lock Handle	1
28	00-478831	Spring – Tension	2
29	SC-124-28	Set Screw M8 x 1.25 x 25mm Slotted Hdls. Dog Pt. (SST)	2
30	00-478820	Handle – Lock	1
31	FE-025-09	Relief – Stain Electrical	1
32	00-479036	Nut – Strain Relief	1
33	00-478853	Cord – Supply (US)	1
34	00-437985	Plug (240 V.)	1
35	00-478827	Roller – Handle Locking	2
36	00-478876	Ring Lock	2
37	00-478900	Housing – Front	1
38	00-478840	Bracket – Angle	1
39	00-087711-00288	Switch – Limit	1
40	SC-124-24	Mach. Screw M3 x 0.5 x 20mm Slotted Pan Hd. (SST)	1
41	00-478903	Housing – Left	1
42	00-478813	Rod – Threaded	4
43	SD-037-41	Self-Tapping Screw 3.5 x 13mm Phil. Oval Hd., Type AB (SST)	6
44	00-478826	Plate – Cover	1
45	00-478873	Seal – Switch Cover	1
46	00-478897	Switch Assy. – Stop	1
47	00-478898	Switch Assy. – Start	1
48	00-087711-00288	Switch – Limit	1
49	SD-038-60	Self-Tapping Screw 4.8 x 9.5mm Phil. Pan Hd., Type AB (SST)	2
50	00-478837	Bracket – Interlock Switch	1
51	SC-124-24	Mach. Screw M3 x 0.5 x 20mm Slotted Pan Hd. (SST)	4
52	00-478874	Spring – Interlock Switch	1
53	00-478839	Plate – Thrust	1
54	00-478838	Shaft – Interlock Switch	1
55	00-087711-00288	Switch – Limit	1
56	00-478875	Seal – O-Ring	1
	00-439923	Wrench – Center Screw	1
	00-479705	Cord – Supply (380-400 V., 50 Hz., 3 Ph.)	1

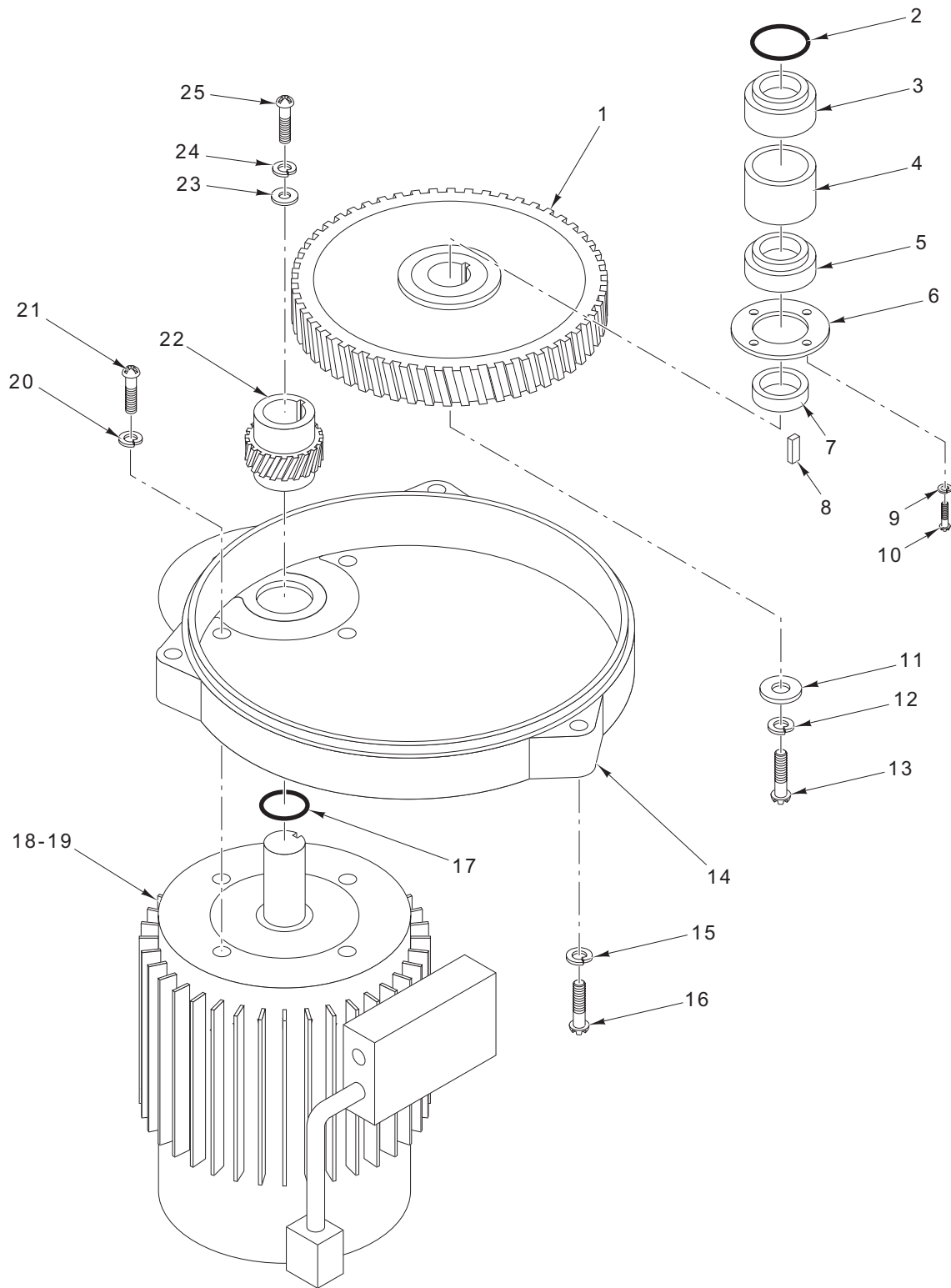

PL-55534

MOTOR AND GEARING

MOTOR AND GEARING

ILLUS. PL-55534	PART NO.	NAME OF PART	AMT.
1	00-478812	Gear – Drive	1
2	00-478871	Ring – Seal	1
3	BB-017-39	Ball Bearing	1
4	00-478810	Ring – Spacer	1
5	BB-021-43	Ball Bearing	1
6	00-478809	Cover – Bearing	1
7	00-478811	Spacer	1
8	00-478872	Key	1
9	WL-019-75	Lockwasher M5 Helical (SST)	4
10	SC-118-37	Mach. Screw M5 x 0.8 x 12mm Slotted Pan Hd. (SST)	4
11	00-478846	Washer	1
12	WL-019-74	Lockwasher M8 Helical (SST)	1
13	SC-121-16	Cap Screw M8 x 1.25 x 22mm Hex Hd. (SST)	1
14	00-478836	Housing – Gear	1
15	WL-019-74	Lockwasher M8 Helical (SST)	3
16	SC 121-56	Cap Screw M8 x 1.25 x 60mm Hex Hd. (SST)	3
17	00-478882	Ring – Seal	1
18	00-478896	Motor (208-240 V., 60 Hz., 3 Ph., UL)	1
19	00-479705	Motor (380-400 V., 50 Hz., 3 Ph.)	1
20	WL-019-74	Lockwasher M8 Helical (SST)	4
21	SC-121-16	Cap Screw M8 x 1.25 x 22mm Hex Hd. (SST)	4
22	00-478821	Gear – Pinion	1
23	00-478847	Washer	1
24	WL-019-89	Lockwasher M10 Helical (SST)	1
25	SC-124-23	Cap Screw M10 x 1.5 x 30mm Hex Hd. (SST)	1

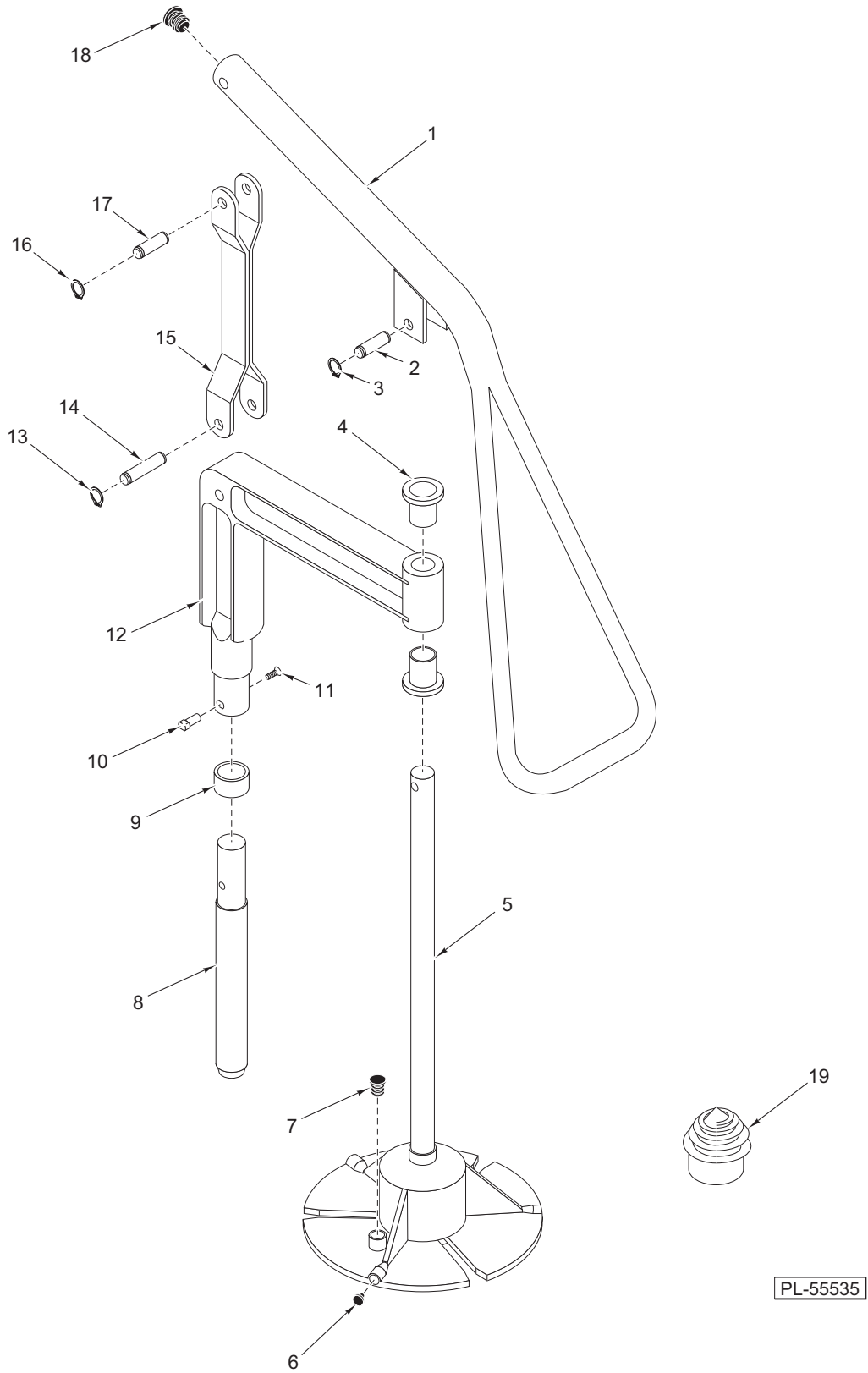

MANUAL PUSH FEED ASSEMBLY

MANUAL PUSH FEED ASSEMBLY

ILLUS. PL-55535	PART NO.	NAME OF PART	AMT.
1	00-478816	Lever	1
2	00-478870	Pin – Pivot (L34)	1
3	00-478880	Ring – Locking	2
4	00-478825	Bushing – Stand	2
5	00-478904	Shaft – Piston Assy.	1
6	00-478864	Knob – Guide	3
7	00-478888	Plug	1
8	00-478814	Stand – Shaft	1
9	00-478819	Bushing	1
10	00-478856	Pin – Stand	1
11	SC-118-36	Mach. Screw M5 x 0.8 x 16mm Slotted Flat Hd. (SST)	1
12	00-478835	Frame – Stand	1
13	00-478880	Ring – Locking	2
14	00-478868	Pin – Pivot (L51)	1
15	00-478815	Link	1
16	00-478880	Ring – Locking	2
17	00-478869	Pin – Pivot (L38)	1
18	00-478888	Plug	1
19	00-478939	Screw – Decoring	1

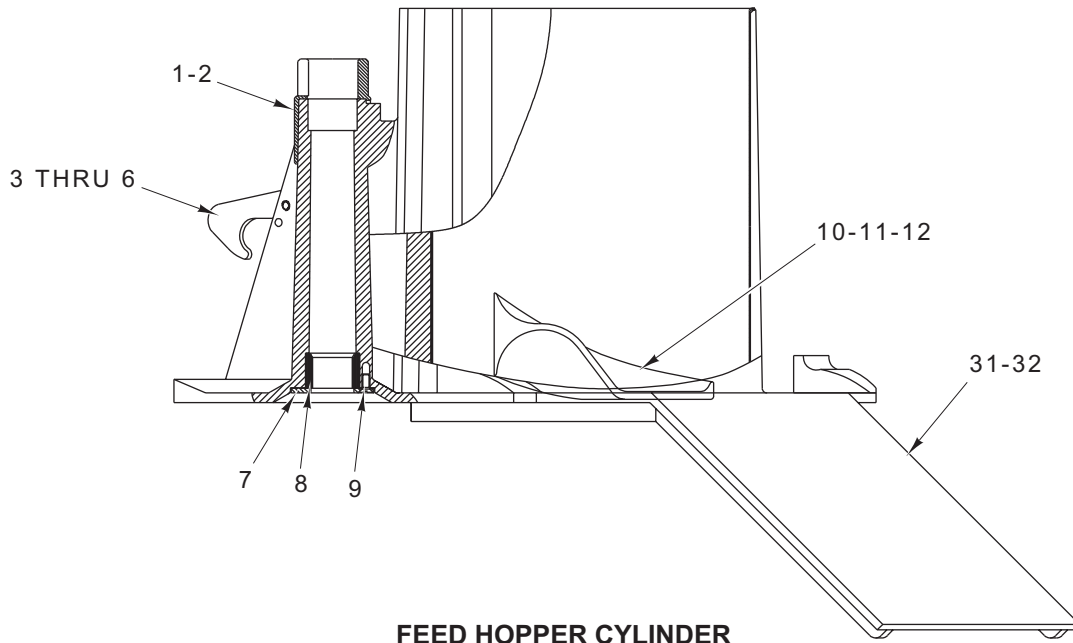

FEED HOPPER CYLINDER

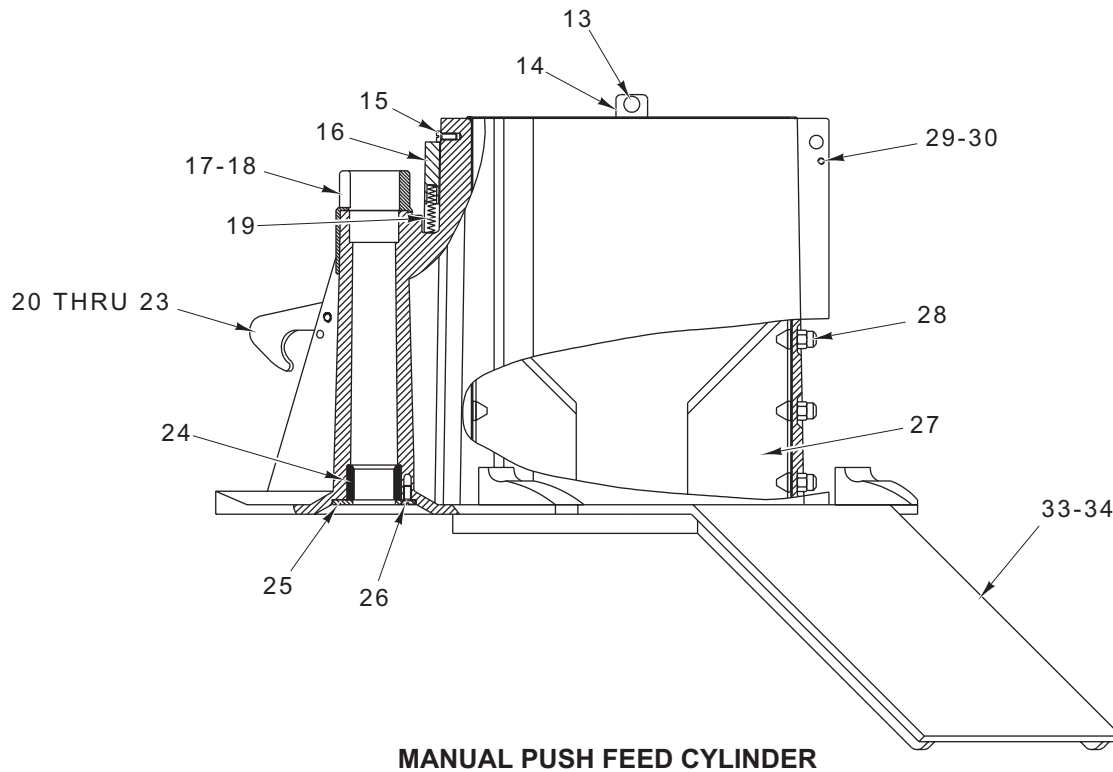

MANUAL PUSH FEED CYLINDER

PL-55586

FEED CYLINDER ASSEMBLIES

FEED CYLINDER ASSEMBLIES

ILLUS. PL-55586	PART NO.	NAME OF PART	AMT.
1	00-478863	Sleeve – Bayonet	1
2	SC-124-30	Mach. Screw M5 x 0.8 x 10mm Slotted Oval Hd. (SST)	2
3	00-478887	Washer	1
4	00-478859	Clutch – Locking	1
5	SC-124-31	Mach. Screw M6 x 1 x 16mm Slotted Truss Hd. (SST)	1
6	00-478867	Washer	2
7	00-478818	Bushing ²⁵ / ₃₄	1
8	00-478817	Cover – Bushing	1
9	SD-038-41	Self-Tapping Screw 4.8 x 13mm Slotted Oval Hd., Type AB (SST)	3
10	00-478857	Guide	2
11	00-478906	Rod – Threaded	4
12	NS-047-34	Nut M6 x 1 Crown (SST)	4
13	00-439121	Rivet – Plastic	2
14	00-478905	Knob – Slide	1
15	SD-037-40	Self-Tapping Screw 3.5 x 9.5mm Slotted Oval Hd., Type AB (SST)	1
16	00-478822	Stopper – Pusher	1
17	00-478863	Sleeve – Bayonet	1
18	SC-124-30	Mach. Screw M5 x 0.8 x 10mm Slotted Oval Hd. (SST)	1
19	00-478879	Spring	1
20	00-478867	Washer	1
21	00-478887	Washer	1
22	00-478859	Clutch – Locking	1
23	SC-124-31	Mach. Screw M6 x 1 x 16mm Slotted Truss Hd. (SST)	1
24	00-478818	Bushing ²⁵ / ₃₄	1
25	00-478817	Cover – Bushing	1
26	SD-038-41	Self-Tapping Screw 4.8 x 13mm Slotted Oval Hd., Type AB (SST)	3
27	00-478842	Knife	3
28	00-478858	Nut – Special Domed	9
29	SC-121-19	Mach. Screw M4 x 0.7 x 16mm Slotted Pan Hd. (SST)	1
30	NS-200-03	Nut M4 x 0.7 Hex (SST)	1
31	00-479085	Feed Hopper Cylinder (US) (Incls. Items 1 thru 12)	1
32	00-479085-00002	Feed Hopper Cylinder (Canada)	1
33	00-478957	Push Feed Cylinder (US) (Incls. Items 13 thru 30)	1
34	00-478957-00002	Push Feed Cylinder (Canada)	1
	00-479094	Knife/Guide Removal Tool	1

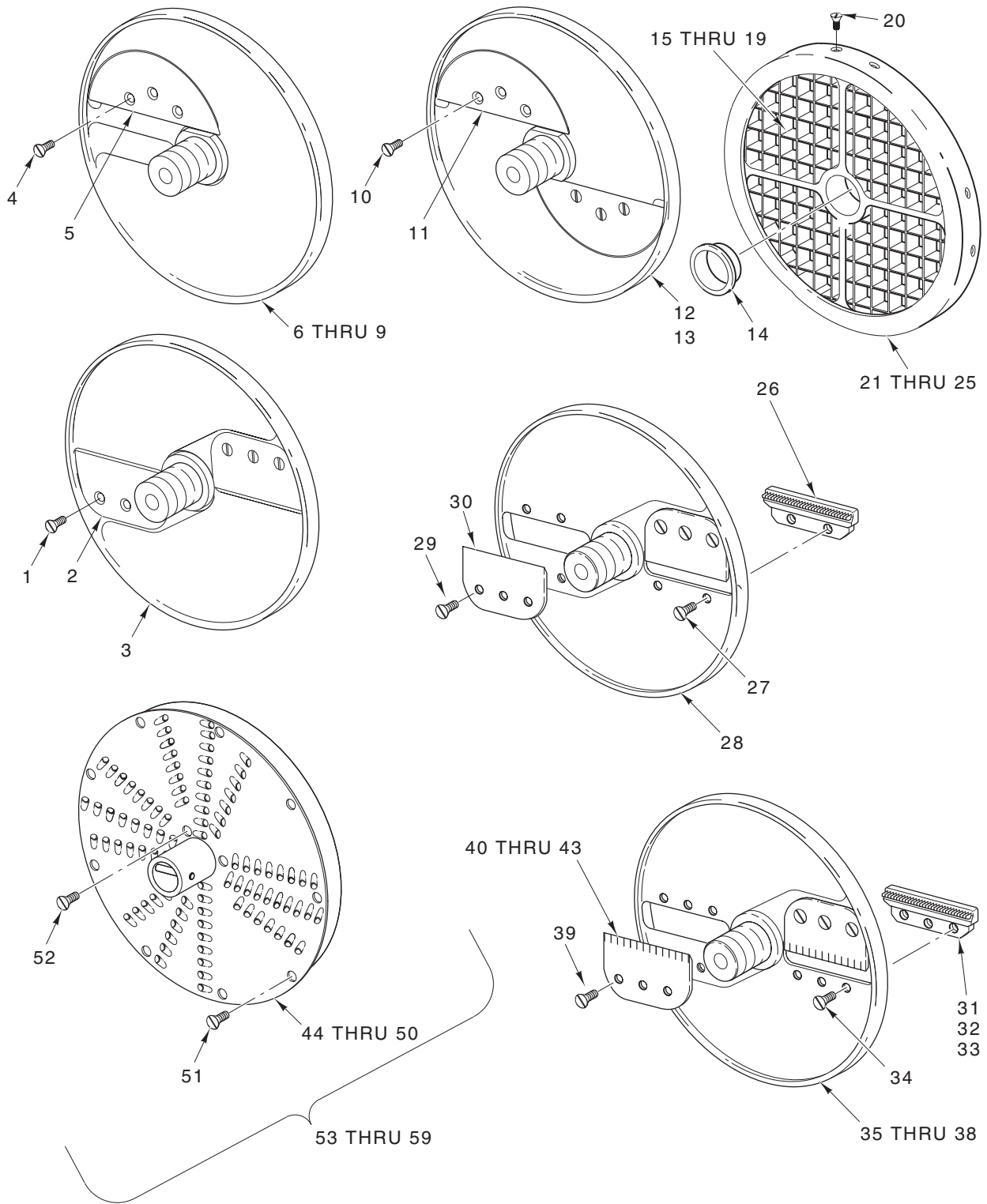

PL-57729

ACCESSORIES

ACCESSORIES

ILLUS.	PART NO.	NAME OF PART	AMT.
PL-57729			
1	SC-120-82	Mach. Screw M5 x 0.8 x 6mm Slotted Flat Hd. (SST)	6
2	00-439157	Knife – Standard Slicer	2
3	00-439298	Plate – Standard Slicer $\frac{3}{8}$ In. (Incls. Items 1 & 2)	1
4	SC-120-82	Mach. Screw M5 x 0.8 x 6mm Slotted Flat Hd. (SST)	3
5	00-439158	Knife – Fine Slicer	1
6	00-439170	Plate – Fine Slicer $\frac{5}{32}$ In. (Incls. Items 4 & 5)	1
7	00-439171	Plate – Fine Slicer $\frac{7}{32}$ In. (Incls. Items 4 & 5)	1
8	00-439172	Plate – Fine Slicer $\frac{9}{8}$ In. (Incls. Items 4 & 5)	1
9	00-439303	Plate – Fine Slicer $\frac{9}{16}$ In. (Incls. Items 4 & 5)	1
10	SC-120-82	Mach. Screw M5 x 0.8 x 6mm Slotted Flat Hd. (SST)	6
11	00-439158	Knife – Fine Slicer	2
12	00-439164	Plate – Fine Slicer $\frac{1}{16}$ In. (Incls. Items 10 & 11)	1
13	00-439169	Plate – Fine Slicer $\frac{1}{8}$ In. (Incls. Items 10 & 11)	1
14	00-875674	Ring – Center	1
15	00-477791	Kit – Knife $\frac{9}{32}$ In.	1
16	00-477792	Kit – Knife $\frac{3}{8}$ In.	1
17	00-477793	Kit – Knife $\frac{1}{2}$ In.	1
18	00-477794	Kit – Knife $\frac{5}{8}$ In.	1
19	00-477795	Kit – Knife $\frac{3}{4}$ In.	1
20	SC-121-13	Mach. Screw M4 x 0.7 x 8mm Slotted Flat Hd. (SST)	8
21	00-477786	Plate – Dicer $\frac{9}{32}$ In.	1
22	00-477787	Plate – Dicer $\frac{3}{8}$ In.	1
23	00-477788	Plate – Dicer $\frac{1}{2}$ In.	1
24	00-477789	Plate – Dicer $\frac{5}{8}$ In.	1
25	00-477790	Plate – Dicer $\frac{3}{4}$ In.	1
26	00-439175	Knife – Balk $\frac{3}{32}$ In.	2
27	SC-120-83	Mach. Screw M4 x 0.7 x 6mm Slotted Flat Hd. (SST)	4
28	00-439174	Plate – Julienne $\frac{3}{4}$ In. (Incls. Items 26, 27, 29, & 30)	1
29	SC-120-82	Mach. Screw M5 x 0.8 x 6mm Slotted Flat Hd. (SST)	6
30	00-439157	Knife – Standard Slicer	2
31	00-439177	Knife – Balk $\frac{3}{16}$ In.	2
32	00-439179	Knife – Balk $\frac{7}{32}$ In.	2
33	00-439162	Knife – Balk $\frac{3}{8}$ In.	2
34	SC-121-13	Mach. Screw M4 x 0.7 x 8mm Slotted Flat Hd. (SST)	6
35	00-439173	Plate – Crimping $\frac{3}{16}$ In. (Not Shown) (Incls. Items 39 & 40)	1
36	00-439176	Plate – Julienne $\frac{3}{16}$ In. (Incls. Items 31, 34, 39, & 41)	1
37	00-439178	Plate – Julienne $\frac{7}{32}$ In. (Incls. Items 32, 34, 39, & 42)	1
38	00-439180	Plate – Julienne $\frac{3}{8}$ In. (Incls. Items 33, 34, 39, & 43)	1
39	SC-120-82	Mach. Screw M5 x 0.8 x 6mm Slotted Flat Hd. (SST)	6
40	00-439159	Knife – Crimping Slicer $\frac{3}{16}$ In. (Not Shown)	2
41	00-439160	Knife – Julienne $\frac{3}{16}$ In.	2
42	00-439161	Knife – Julienne $\frac{7}{32}$ In.	2
43	00-439163	Knife – Julienne $\frac{3}{8}$ In.	2
44	00-439143	Insert – Fine Grater	1
45	00-439145	Insert – Shredder Plate $\frac{1}{16}$ In.	1
46	00-439146	Insert – Shredder Plate $\frac{3}{32}$ In.	1
47	00-439147	Insert – Shredder Plate $\frac{1}{8}$ In.	1
48	00-439148	Insert – Shredder Plate $\frac{3}{16}$ In.	1
49	00-439149	Insert – Shredder Plate $\frac{7}{32}$ In.	1
50	00-439150	Insert – Shredder Plate $\frac{5}{16}$ In.	1
51	SC-120-85	Mach. Screw M3 x 0.5 x 6mm Slotted Flat Hd. (SST)	9
52	SC-120-85	Mach. Screw M3 x 0.5 x 6mm Slotted Flat Hd. (SST)	3
53	00-439144	Plate – Fine Grater (Incls. Items 44 & 51)	1
54	00-439151	Plate – Shredder $\frac{1}{16}$ In. (Incls. Items 45, 51, & 52)	1
55	00-439152	Plate – Shredder $\frac{3}{32}$ In. (Incls. Items 46, 51, & 52)	1
56	00-439153	Plate – Shredder $\frac{1}{8}$ In. (Incls. Items 47, 51, & 52)	1
57	00-439154	Plate – Shredder $\frac{3}{16}$ In. (Incls. Items 48, 51, & 52)	1
58	00-439155	Plate – Shredder $\frac{7}{32}$ In. (Incls. Items 49, 51, & 52)	1
59	00-439156	Plate – Shredder $\frac{5}{16}$ In. (Incls. Items 50, 51, & 52)	1
	00-439297	Plate – French Fry $\frac{3}{8}$ In. (Not Shown)	1
	00-274372	Wall Rack (Incls. Label)	1
	00-435091	Work Table	1
	00-333692	Foot – Adjustable	1
	00-333691	Insert – Leveler	1

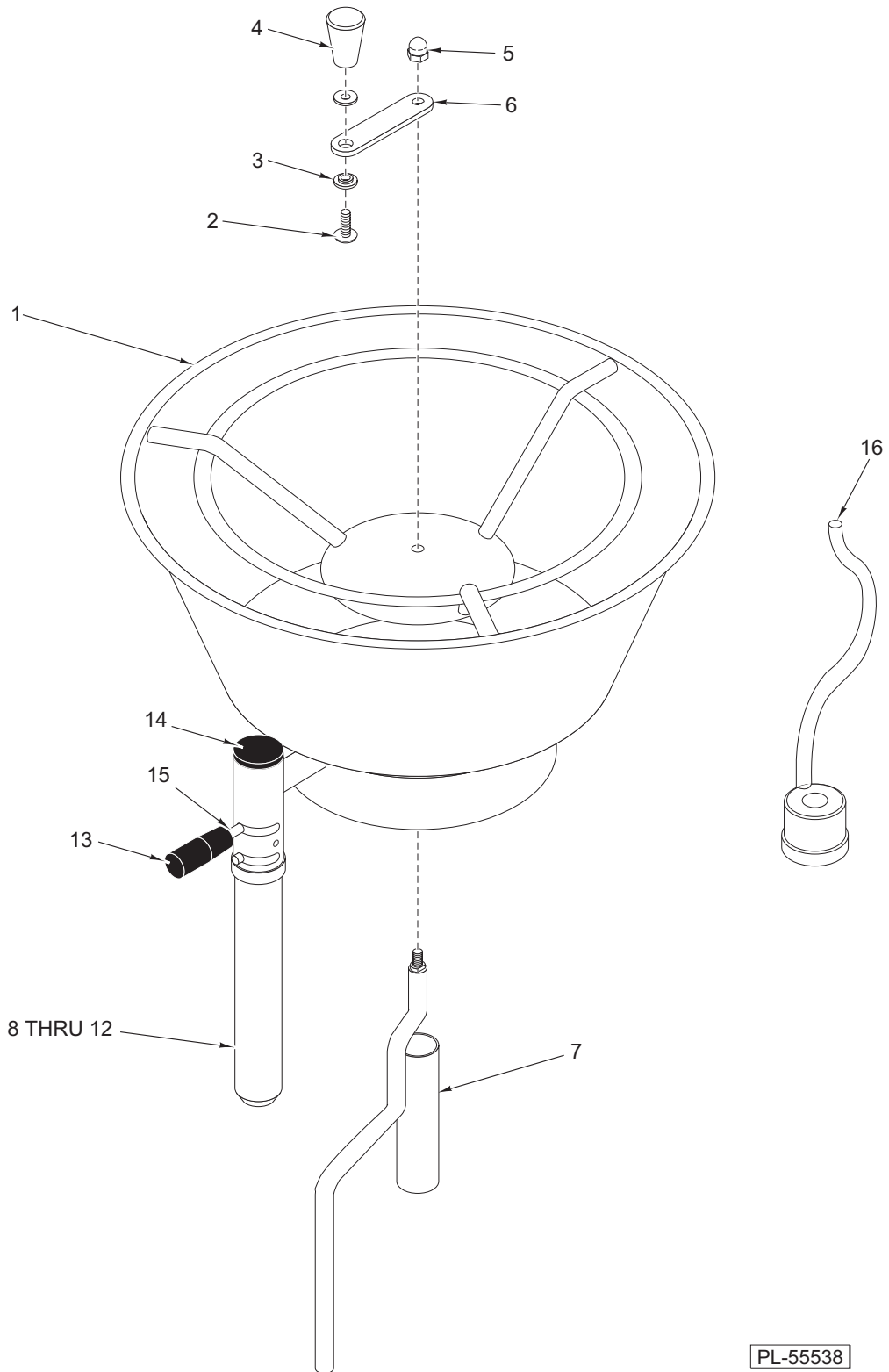

FEED HOPPER ASSEMBLY

PL-55538

FEED HOPPER ASSEMBLY

ILLUS. PL-55538	PART NO.	NAME OF PART	AMT.
1	00-478848	Insert – Hopper	1
2	SC-124-31	Mach. Screw M6 x 1 x 16mm Slotted Truss Hd. (SST)	1
3	00-478867	Washer	2
4	00-478866	Knob – Crank	1
5	NS-047-34	Nut M6 x 1 Crown (SST)	1
6	00-478861	Crank – Hopper	1
7	00-478860	Lever – Stir	1
8	00-478824	Shaft	1
9	00-478865	Bushing	1
10	00-478841	Pin – Bayonet	1
11	00-478889	Spring	1
12	00-478890	Ball	1
13	00-478883	Handle	1
14	00-478884	Plug	1
15	00-477254	Screw – Handle	1
16	00-478862	Agitator – Screw (Use to Secure Cutting Plates)	1

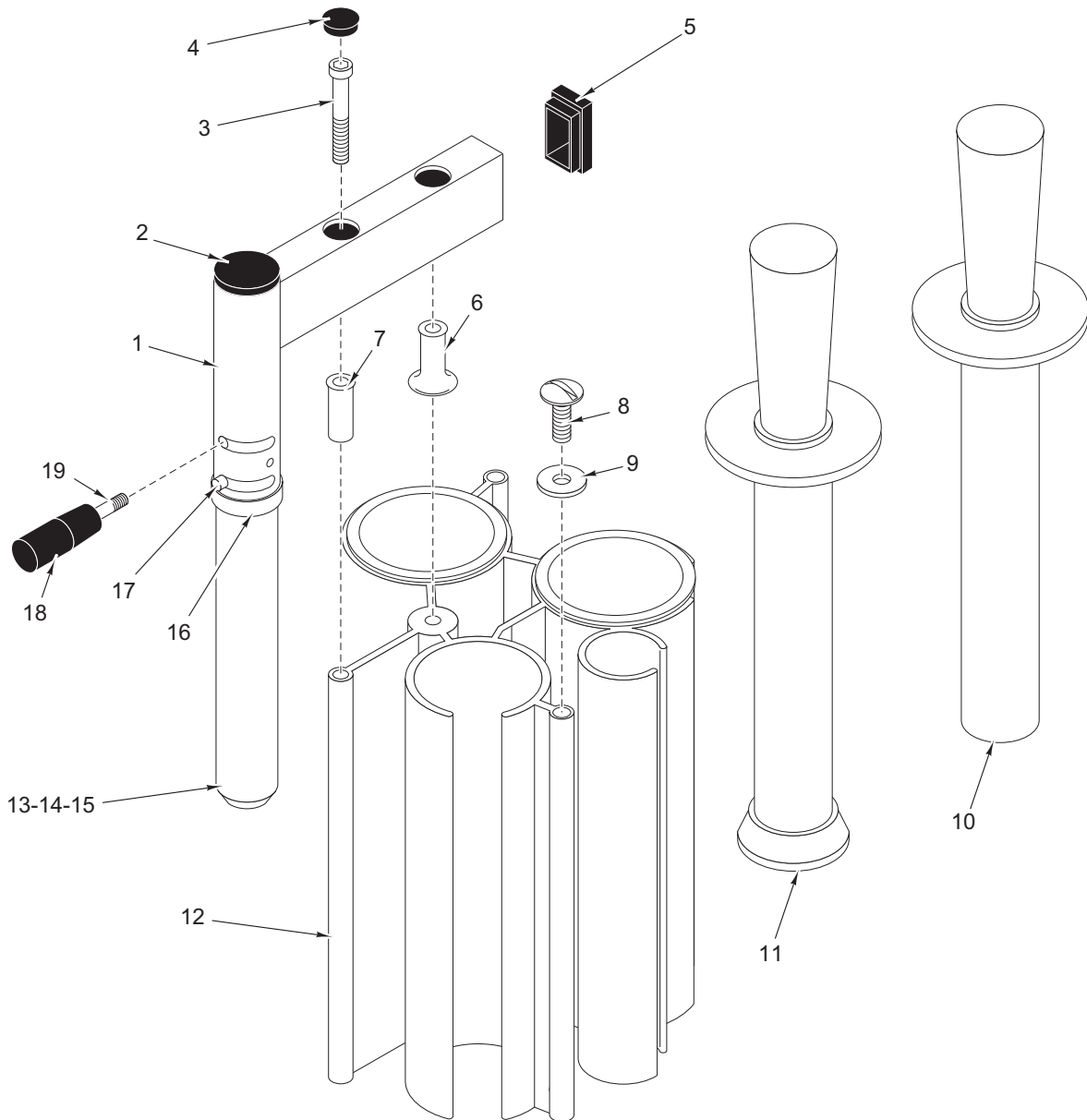

PL-55539

TUBE FEED ASSEMBLY

TUBE FEED ASSEMBLY

ILLUS. PL-55539	PART NO.	NAME OF PART	AMT.
1	00-479576	Stand – Tube Feeder	1
2	00-478884	Plug	1
3	SC-117-18	Cap Screw M8 x 1.25 x 40mm Soc. Hex Hd.	2
4	00-479574	Plug (1 KPT)	2
5	00-479573	Plug – Rectangle (IR20)	1
6	00-479572	Spacer – Flanged (25)	1
7	00-479571	Spacer (16)	1
8	SC-119-03	Mach. Screw M8 x 1.25 x 16mm Slotted Mushroom Hd. (SST)	2
9	00-479570	Washer – Special	2
10	00-479567	Plunger – Narrow	1
11	00-479568	Plunger – Wide	1
12	00-479575	Insert – 4 Tube	1
13	00-478824	Shaft	1
14	00-478889	Spring	1
15	00-478890	Ball	1
16	00-478865	Bushing	1
17	00-478841	Pin – Bayonet	1
18	00-478883	Handle	1
19	00-477254	Screw – Handle	1
	00-479569	Bolt – Locking (Use to Secure Cutting Plates)	1

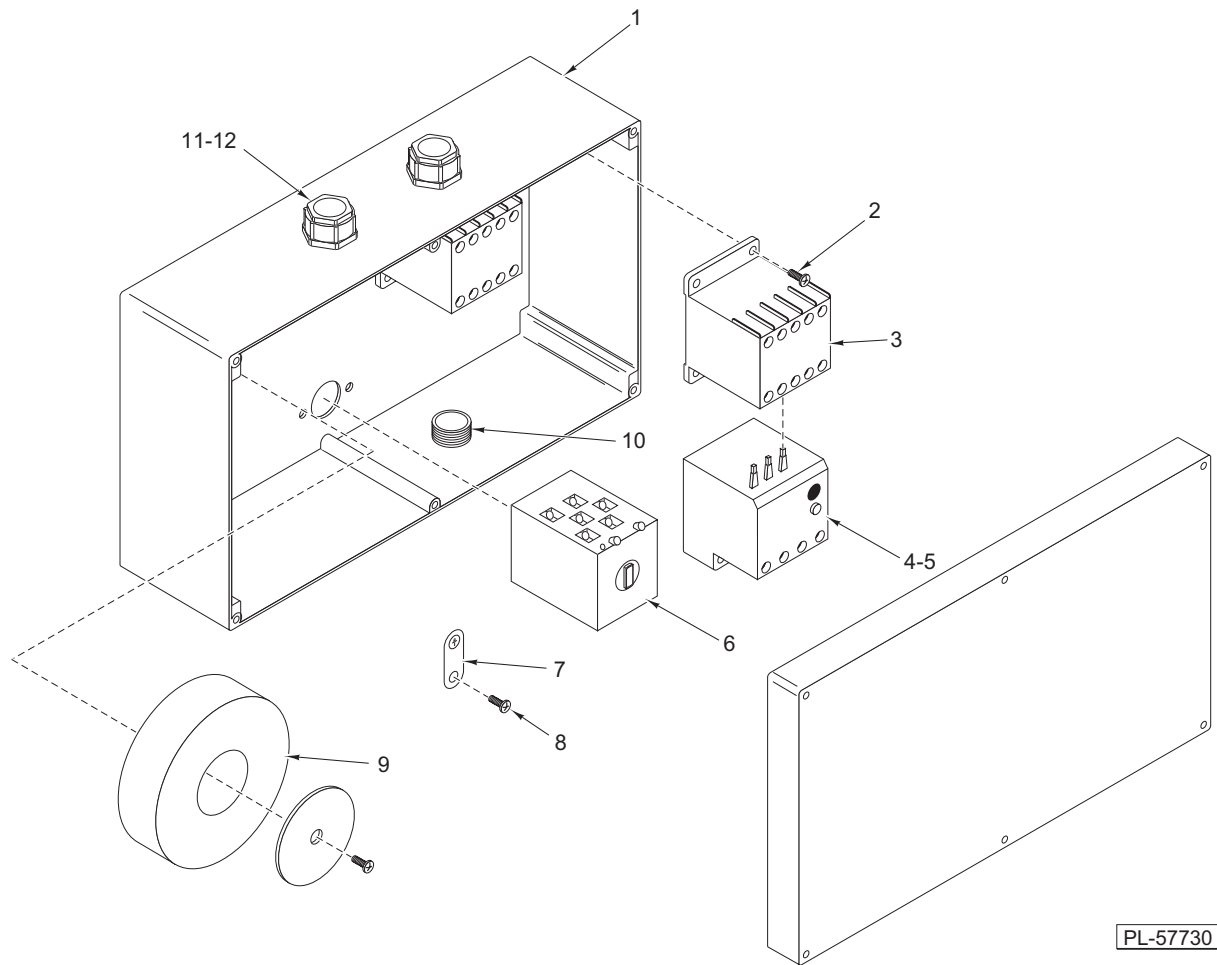

ELECTRICAL BOX ASSEMBLY

ILLUS. NO.	PART NO.	NAME OF PART	AMT.
1	00-478899	Box – Electrical (With Lid)	1
2	SC-118-28	Mach. Screw M4 x 0.7 x 12mm Slotted Pan Hd. (SST)	3
3	00-087713-089-4	Contactor (24 VAC)	2
4	00-479102	Relay – Overload (208 V.)	1
5	00-088196-017-6	Relay – Overload (380 V.)	1
6	00-479035	Switch – Speed Assy. (Includes Hardware)	1
7	00-478892	Plate – Ground	1
8	SC-124-29	Mach. Screw M3 x 0.5 x 12mm Slotted Flat Hd. (SST)	1
9	00-478907	Transformer (208-240 V.)	1
10	00-478894	Seal – Cable	2
11	00-478893	Seal – Cable	1
12	00-478895	Nut – Special	2