

**HOBART**701 S Ridge Avenue, Troy, OH 45374  
1-888-4HOBART • www.hobartcorp.com**4822  
MEAT CHOPPER****HOBART****STANDARD FEATURES**

- 120/60/1
- 1½ H.P. Motor
- 12-20 Lbs. per Minute Capacity
- Ideal for "On Demand" Meat Chopping for Processing Fresh, Boned Meat
- Can Be Fed at a Rapid Pace with Continuous Chopping Action and No Crushing or Mashing of the Meat
- All Parts Which Contact Food are Easily Accessible and Readily Removable for Convenient Cleaning Without the Use of Tools
- 6 ft. Flexible Cord and Plug

**OPTIONS**

- 240/60/1
- 208-240/60/3
- 480/60/3

**MODEL**

- 4822 – Meat Chopper

Specifications, Details and Dimensions on Back.



4822



4822 with Optional Funnel Shaped Cylinder

**4822 MEAT CHOPPER**

# 4822 MEAT CHOPPER



701 S Ridge Avenue, Troy, OH 45374  
1-888-4HOBART • www.hobartcorp.com

## SPECIFICATIONS

**MOTOR:** 1½ H.P. designed expressly for this unit, has grease-packed ball bearings. Protected by machine enclosure, ventilation is provided through openings in the base covered by perforated metal screens (¼" diameter holes). Single phase is capacitor-start, capacitor-run, induction type. Three phase is poly-phase, induction type. See standard electrical specifications shown below. Not available in D.C.

**SWITCH:** Conveniently mounted at back of machine (can be changed to front).

**CORD AND PLUG:** A 6 foot, flexible cord and plug for grounding is furnished for 60 Hz, single and three-phase machines. A 3-wire I.E.C. cord is furnished on 50 Hz. single-phase.

**TRANSMISSION:** Precision made gears and shafts mounted on ball bearings are fully enclosed in the transmission case, packed with a special oil at the factory. Smooth, quiet operation is assured for years of normal operation.

The attachment hub has a double seal, designed to exclude meat juices or water from the transmission. Worm speed is 212 r.p.m.

**CHOPPING END:** 4822 has a Hobart protective type chopping end, with cylinder of the spiral-fluted design. FS option has a guarded open bowl type chopping end. A heavy cast aluminum

safety guard is supported by vertical posts permanently mounted on the cylinder. The cylinder, worm and adjusting ring are all heavily tinned. A heat-treated steel knife and plate and plastic feed stomper.

**FEED PAN:** 4822 has a stainless steel feed pan — 19½" x 11½" x 2½" inside dimensions. FS option has stainless steel pan — 33" x 15¼" x 3¼" inside dimensions.

**CAPACITY:** 4822 will grind 16 lbs. per minute, first cutting through a ⅛" plate. FS option will grind 20 to 22 lbs. per minute, first cutting through a ⅛" plate.

**FINISH:** Standard finish is stainless steel housing. An attractive stainless steel trim plate is provided at the attachment opening and stainless steel legs, cushioned on the bottom with resilient neoprene rubber, provide clearance to keep the table clean under the chopping unit.

**STANDARD EQUIPMENT:** Includes the working unit with protective type tinned chopping end, stainless steel feed pan, plastic feed stomper, one knife and one plate. The plate has ⅛" diameter holes.

**OPTIONAL EQUIPMENT:** Stay-Sharp knife and plate.

**WEIGHT:** Net weight, 186 lbs. Approx. shipping weight, 105 lbs.

## DETAILS AND DIMENSIONS

### WARNING

ELECTRICAL AND GROUNDING CONNECTIONS MUST COMPLY WITH APPLICABLE PORTIONS OF THE NATIONAL ELECTRICAL CODE AND/OR OTHER LOCAL ELECTRICAL CODES.

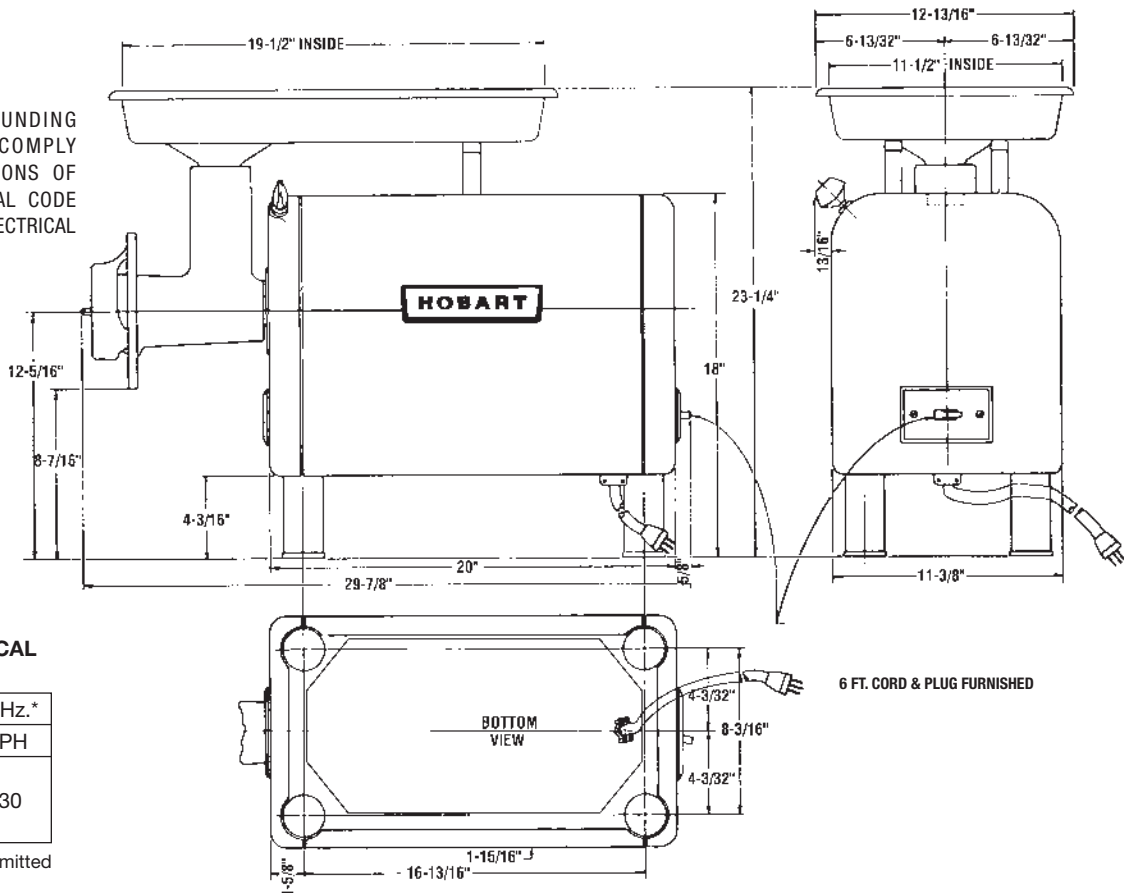

### STANDARD ELECTRICAL SPECIFICATIONS

60 Hz.		50 Hz.*
1 PH	3 PH	1 PH
120	208	230
240	240	
	480	

\*50 Hz. machines not submitted for UL listing.

As continued product improvement is a policy of Hobart, specifications are subject to change without notice.